

**STEP 1: Install wheel pants with typical installation**

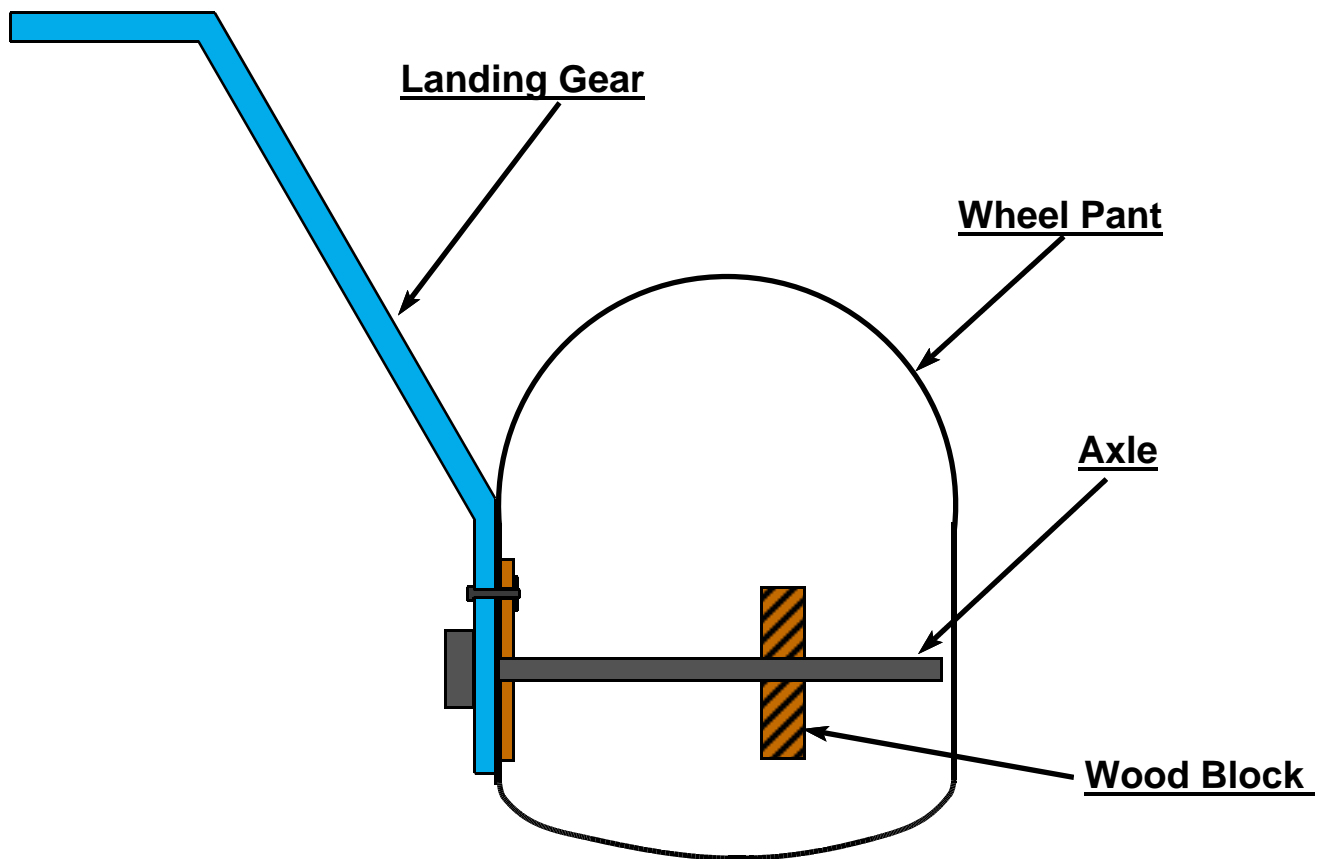

**STEP 2:** Make a small block of wood (balsa or lite ply) about 1"x1-1/2"x1/4", and drill a hole the size of the axle in the center.

Remove the wheel, and re-install the wheel pants with the small wood block inserted loosely on the axle.

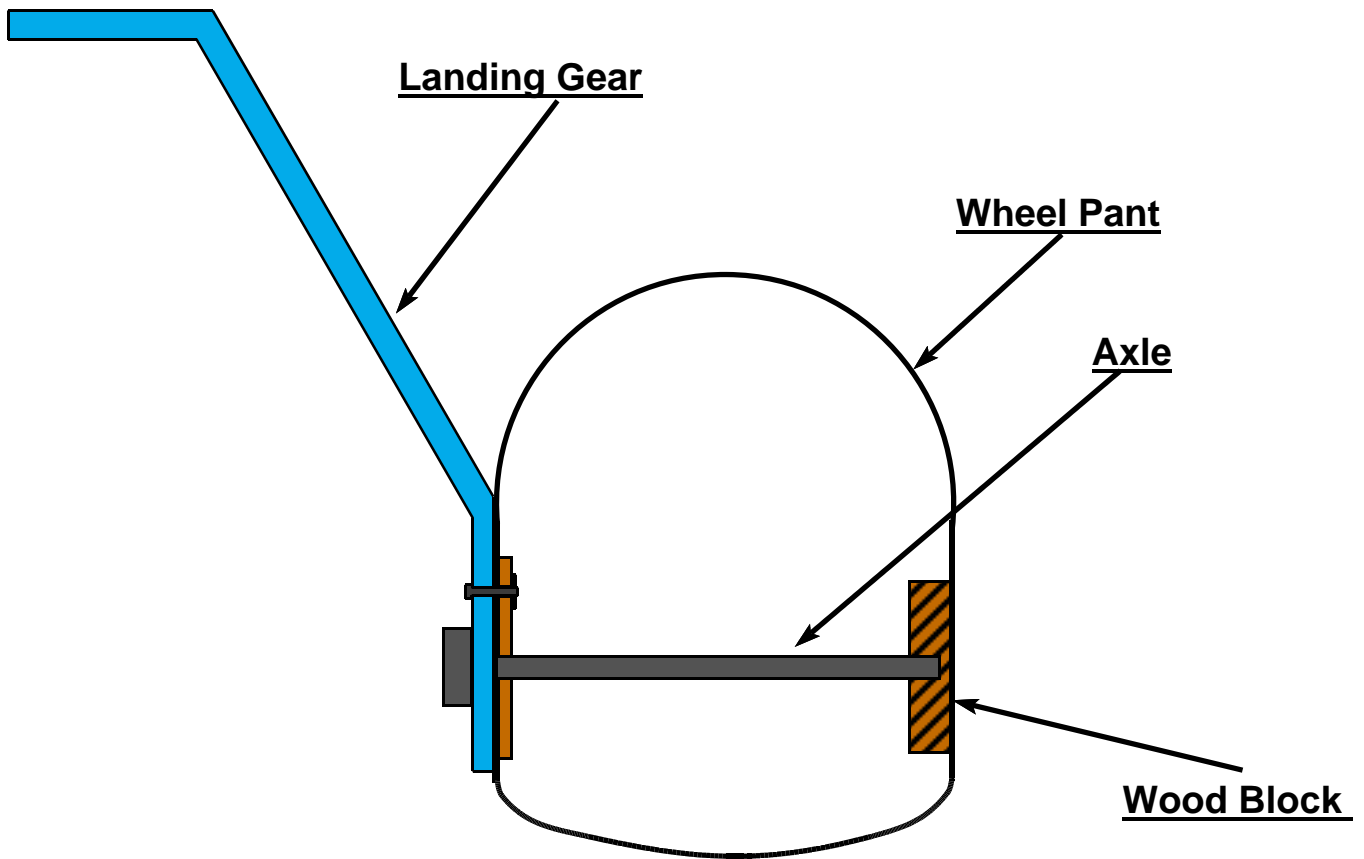

**STEP 3: Glue the wood block the wheel pants using epoxy, making sure the wheel pants screws are tight, the wheel pants are seated in their "natural" position, with no stress on the fiberglass. If using a soft wood, it is helpful to harden the wood at the hole for the axle with thin CA.**

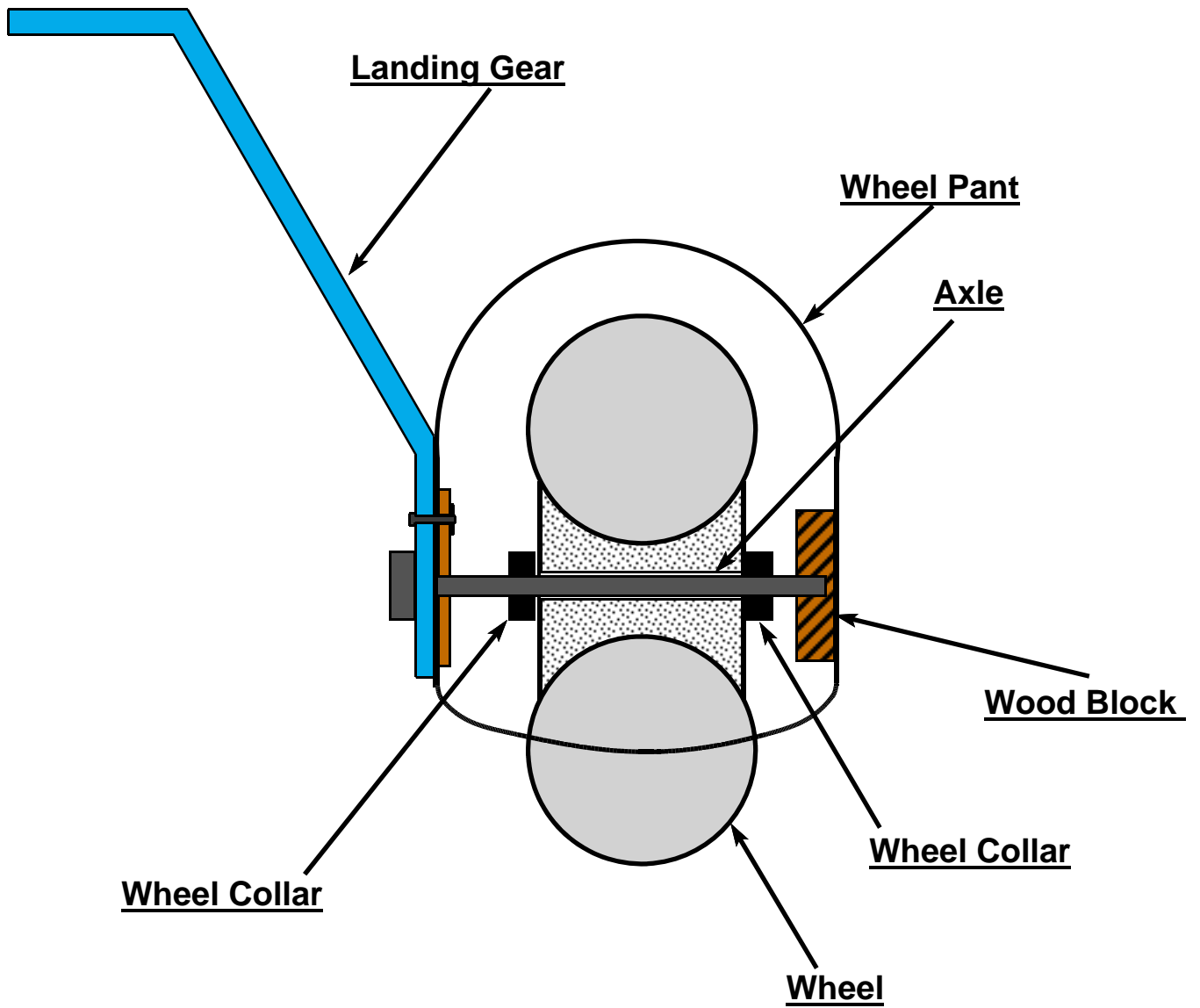

**STEP 4: Re-install all components to complete assembly**